

Publication 351-05010-00B, 06/21/05

Instruction Manual

Installation • Operation • Maintenance

Field Failure and Out-of-
Step Protection Assembly
for a Synchronous Motor
511-01111-25



Leroy Somer North America

Kato Engineering Inc.
P.O. Box 8447
Mankato, MN USA
56002-8447
Tel: 507-625-4011
Fax: 507-345-2798
Email: katoengineering@lsusa.com
www.kato-eng.com

Note: Because of rapid changes in designs and processes and the variability of Kato Engineering's products, information in this manual must not be regarded as binding and is subject to change without notice.

General Description

The field failure and out-of-step protection assembly is used with a brushless synchronous motor to protect it from damage when the motor loses synchronism. A brushless synchronous motor is designed to produce its rated power only when it is operating synchronously with the power applied to its armature windings (i.e., a 1200 rpm, 60 Hz motor must operate at 1200 rpm; it cannot be allowed to operate at 1190 rpm with 60 Hz power applied). The only reason this type of motor would operate at other than rated speed is if the load on the motor were greater than its capabilities with a given field current and armature voltage applied. If this occurs, the motor must be disconnected from the power source very quickly or serious damage to the motor could result.

This device detects the high-amplitude, short-duration current pulses, which will occur when the motor pulls out of step (loses speed). A motor may lose speed due to either severe overload or loss of field (caused by rotating rectifier failure, exciter winding failure, etc.). See Figure 1 for an outline diagram.

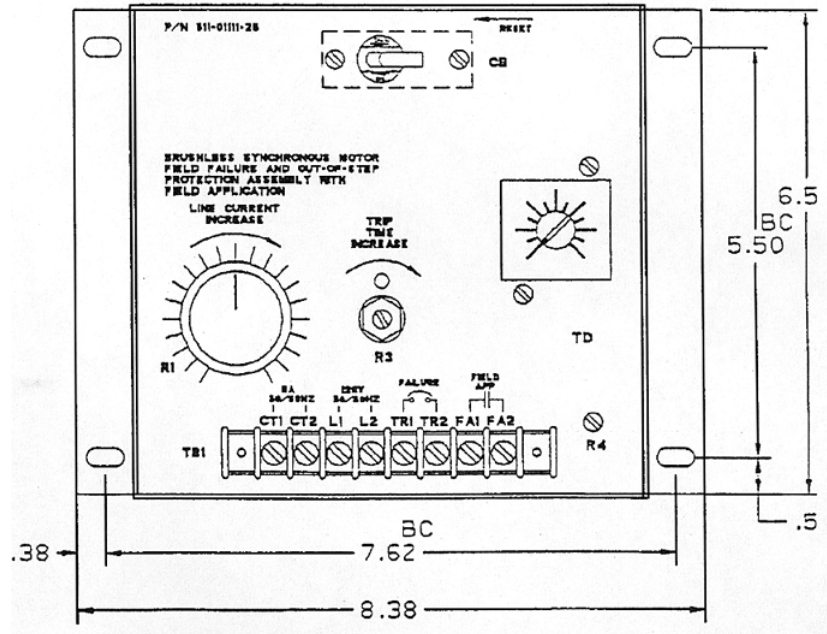

Figure 1: Outline diagram

Connection

Refer to Figure 2 for a connection diagram.

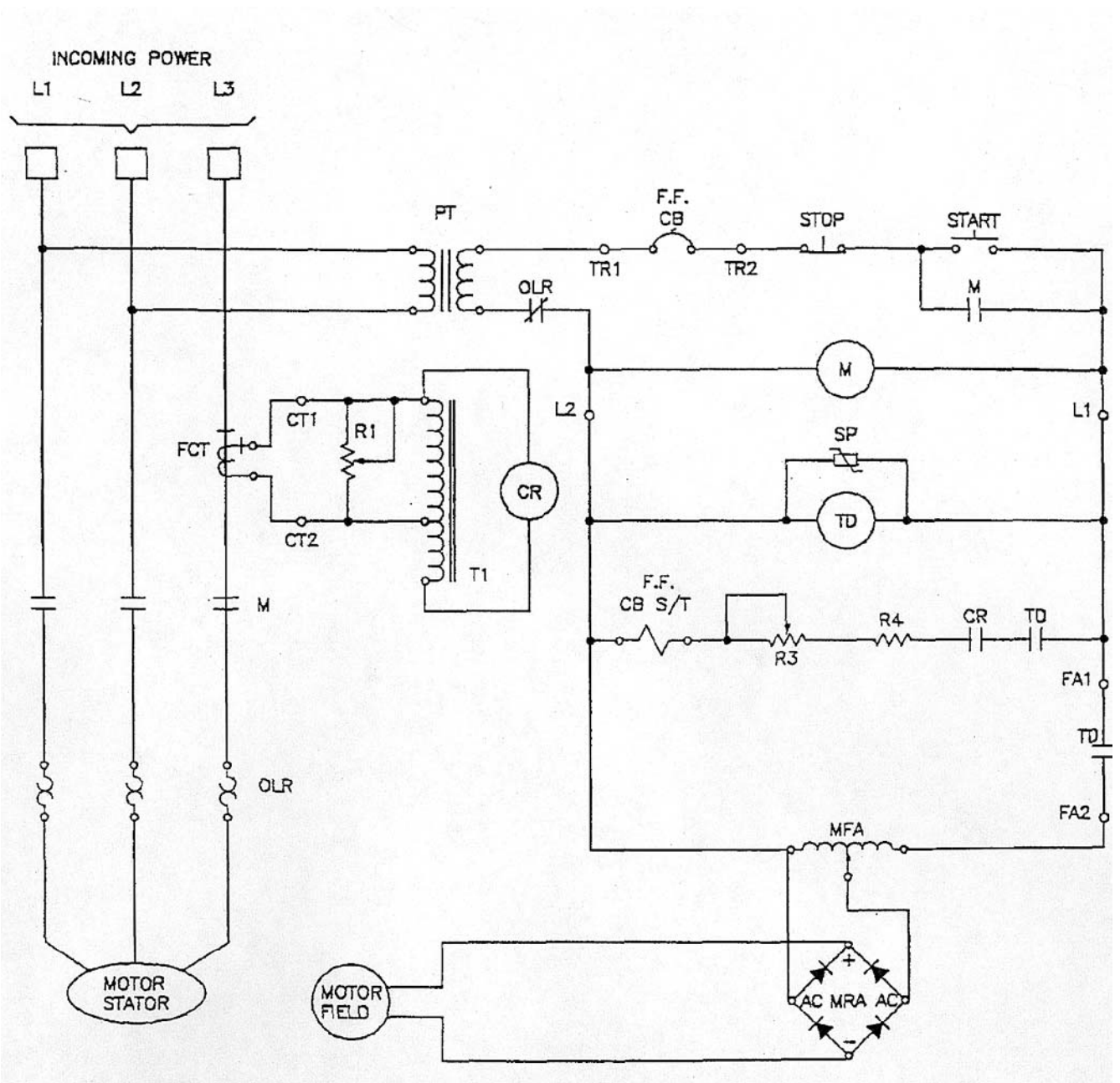

Figure 2: Connection diagram

Operation

Refer to Figures. 2 and 3 for a typical circuit. When the motor start button is pressed, the motor starter will be energized and power will be applied to terminals L1 and L2 of the field failure and out-of-step protection assembly, energizing timer TD. Due to the starting current of the motor, relay CR will energize, and its contact will close, but will not complete a circuit to the trip coil of the circuit breaker (CB) until the timing cycle of TD is completed and its contacts close. Normally, the motor starting current surge will have subsided, opening the contacts of CR before the contacts of TD close. When TD's contacts do close, power will be applied to the motor field circuit, and the motor will operate normally.

If at any time after TD's timing cycle has expired and abnormal current surge occurs, relay CR is energized and its contacts close. This applies power to the trip coil of CB. The trip characteristics of CB are such that it will allow from 1 to 3 of these surges before it trips. This prevents nuisance tripping due to switching surges on the power line or current surges due to application of large block loads. When CB trips, it opens the circuit to the motor starter coil and thereby removes power from the motor. A surge protector SP is placed across the input to TD to protect it from damaging voltage transients above a certain level.

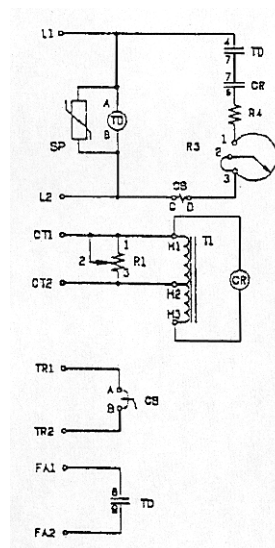

Figure 3: Electrical schematic

Reset After Trip

When the circuit breaker (CB) trips, determine the cause of the out-of-step condition and make corrections. The CB may then be reset, and the motor can be restarted.

Adjustments

Line current sensitivity potentiometer R1 - This resistor is to be set so that relay CR will be energized at the desired motor line current value. This will normally be approximately 100% of motor full load current. Turn R1 clockwise if relay CR energizes at too low a line current. Turn R1 counterclockwise if line current reaches a higher-than-desired pickup point before relay CR energizes.

Time delay relay (TD) - Set this with sufficient delay time to permit field application immediately after the motor reaches synchronous speed.

Trip time control potentiometer R3 - This potentiometer controls the trip time of the circuit breaker providing a means of manually adjusting the voltage applied across the circuit breaker shunt trip. Its purpose is to cause the circuit breaker to function in the same manner as a time delay fuse. This feature prevents nuisance tripping during short duration transients. Turning R3 provides a longer time delay.

Maintenance

Refer to Table 1 for the list of replacement parts.

Key no.	Description	Part Number	Quantity
TB1	Terminal strip	531-30311-08	1
R1	Potentiometer 0.5 Ω , 50 W	867-05035-23	1
T1	Current transformer	858-21019-00	1
R3	Potentiometer, 1 k Ω , 25 W	867-41075-22	1
R4	Resistor, 150 Ω , 25 W	865-31575-13	1
TD	Relay 120 Vac	846-02529-08	1
CR	Current relay 60 mA	505-41310-27	1
CB	Circuit breaker	510-90015-55	1
SP	Surge protector	854-10640-03	1

Table 1: List of replacement parts