

INSTRUCTION MANUAL

FOR

DIODE FAULT DETECTOR

Part Number: 508-00118-40
508-00118-41
508-00118-42
508-00118-44
508-00118-45
508-00118-46 (7-95)
508-00118-47 (7-99)
508-00118-50 (12-95)
508-00118-52 (3-98)

KATO ENGINEERING



P.O. BOX 8447
MANKATO, MN 56002-8447
(507) 625-4011
FAX (507) 345-2798

DIODE FAULT DETECTOR ASSEMBLY

OPERATION

The diode fault detector (DFD) protects the generator exciter against damage due to diode failures such as open, shorted, or leaky exciter diodes. The detector can be connected such that the failure will sound an alarm or remove excitation from the generator and open the generator circuit breaker. Kato Engineering recommends that the DFD be connected to an alarm on an open diode and to shut down the generator excitation when a shorted diode is detected.

SPECIFICATIONS

Input Power: Single phase, 120 VAC or 240 VAC, 50-180 Hz, 10 VA

Field Current: 7.5 Amps DC maximum

Output Contact Ratings: 1.5 Amps maximum @ 24VDC or 115VAC

CONNECTIONS (Figure 1)

The voltage regulator and DFD are powered from a PMG (permanent magnet generator) or generator to provide a continuous power source. Four form C (SPDT) relay contacts are provided for customer use.

CIRCUIT DESCRIPTION (Figure 2)

The AC components of the exciter field current are coupled to the DFD circuit board by input transformer T2. The 4 pole, band-pass filter selectively amplifies the fundamental frequency of the exciter output frequency. In normal operation, the generator exciter diodes induce negligible exciter frequency content into the exciter field current. When an exciter diode opens, the energy at the exciter frequency coupled into the exciter field current doubles. When an exciter diode becomes shorted, the exciter frequency content increases by approximately ten times. The rectifier converts this signal to a dc voltage. The level detector compares this dc voltage to the trip level set by the sensitivity control. The appropriate level detector changes state and signals the relay driver when an exciter diode failure has occurred. The open diode relay driver has a three second time delay before the relay is actuated and the yellow LED is illuminated. The shorted diode relay driver has less than a second time delay before the relay is actuated and the red LED is illuminated.

MOUNTING

This unit can be mounted in any position.

ADJUSTMENTS

If the DFD was supplied and tested with the generator, it will function properly without further adjustment. If the DFD was supplied separately, it will be necessary to set the “dip” switches located on the circuit board, as described below. It may also be necessary to reduce the sensitivity of the DFD once the generator is operating, as described in the “CHECKOUT” section. The switch settings are determined from the number of exciter poles, the generator speed (RPM), and the power source frequency. To determine the number of exciter poles, match the first four digits of the Exciter Field Assembly part number to the chart below. The Assembly part number can be found on the Bill of Material or the Replacement Parts List supplied with the generator instruction manual.

Exciter Field Assembly No.	No. of Exciter Poles
230-9xxxx-xx *	4,8,14
230-1xxxx-xx	14
230-2xxxx-xx	28
230-3xxxx-xx	24
230-6xxxx-xx	14

* Consult factory — Refer Kato S/N

The power source for the DFD must be either the PMG, if one is included, or the generator. Determine the generator RPM and the frequency of the PMG, if included, or the frequency of the generator (if it does not have a PMG), from the generator nameplate. Divide the RPM by the power source frequency to obtain one of the values in the header of the chart below. The correct switch setting appears at the intersection of that column with the row corresponding to the number of exciter poles.

Dip Switch Settings

NUMBER OF EXCITER POLES	<u>RPM</u> POWER SOURCE FREQ. (GENERATOR OR PMG)						
	60	30	20	15	12	10	5
4	5,6,9	6,7,10	6,11,12	7,8,11	7,9	7,12	8,12
8	4,5,8	5,6,9	5,10,12	6,7,10	6,8	6,11,12	7,12
12	3,6,8,9	4,7,9,10	5,6,9	5,8,10,11	6,7,8,9	6,7,10	7,8,11
14	3,5,7,8,9,10	4,6,8,9,10,11	5,6,7,9,12	5,7,9,10,11,12	5,9,10	6,7,8,10,12	7,8,9,11
24	2,5,7,8	3,6,8,9	4,5,8	4,7,9,10	5,6,7,8	5,6,9	6,7,10
28	2,4,6,7,8,9	3,5,7,8,9,10	4,5,6,8,11,12	4,6,8,9,10,11	4,8,9	5,6,7,9,12	6,7,8,10,12

The dip switch position numbers indicated above are in the “closed” or “on” position.

The dip switch position numbers not indicated above are in the “open” or “off” position.

CHECKOUT

To be sure that the diode fault detector will function properly, perform the following checkout procedure.

1. Start the generator set. Verify that the green status LED is on and that the diode fault detector will not trip under normal full load operation.
2. If the DFD trips showing an open or shorted diode condition, shut down the generator and verify that there are no open or shorted diodes. If the DFD tripped on an open diode condition and upon inspection none was found, turn the adjustment for R1 on the DFD circuit board 1 turn counterclockwise. Restart the generator set and verify that the DFD does not trip showing an open diode condition. This procedure may have to be repeated a number of times.
3. Shut down the generator.

WARNING

BE SURE THE GENERATOR IS SHUT DOWN BEFORE ATTEMPTING TO INSPECT, TROUBLESHOOT, OR REPAIR THE EXCITER DIODE ASSEMBLY. FAILURE TO FOLLOW THIS WARNING COULD RESULT IN SERIOUS INJURY OR ELECTROCUTION.

4. Disconnect one exciter diode lead to simulate an open diode condition.

NOTE: There is an insulated terminal where the heatsink outer edge is marked red. Remove hardware and install exciter diode lead and reassemble all hardware (See Figure 4, page 7).

5. Restart the generator. The diode fault detector should detect the open diode indicated by the yellow LED lighting and trip to actuate controls that shut down the generator. Remember to reconnect the diode before restarting the generator set, observing the WARNING above.

If the diode fault detector fails to trip the generator controls, shut down the generator and contact a Kato Engineering Representative for further instructions.

REPAIR AND REPLACEMENT

Because of the difficulty of making repairs on a conformal coated printed circuit board, replacement rather than repair is recommended. If a replacement diode fault detector is required, order from Kato Engineering Company, Parts and Service Department. Please be sure to specify the Kato part number when ordering.

FIGURE 1
TYPICAL CONNECTION DRAWING

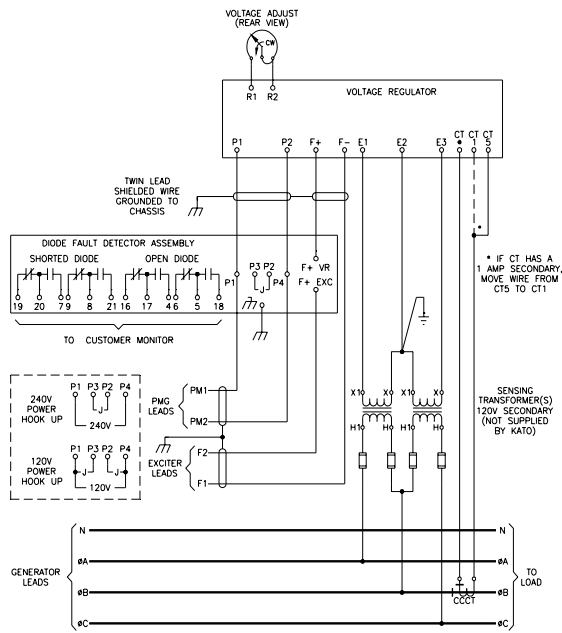
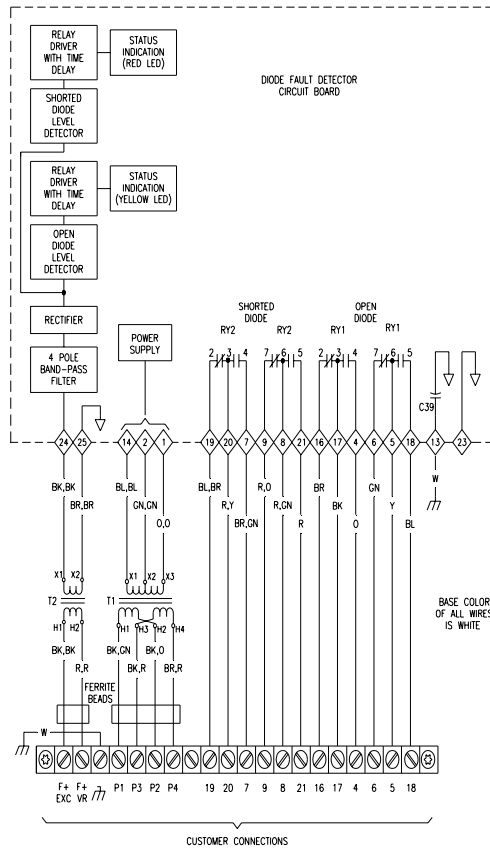
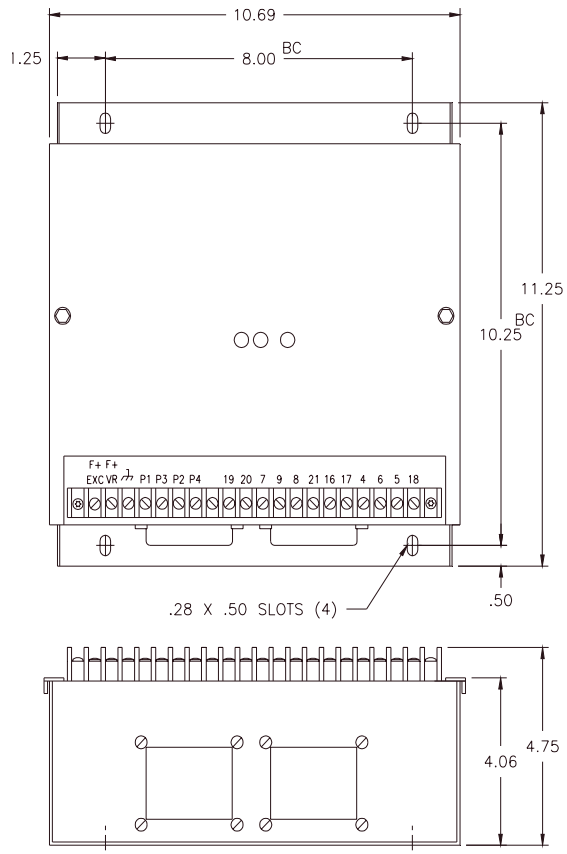

FIGURE 2





DIMENSIONAL DRAWING

FIGURE 3

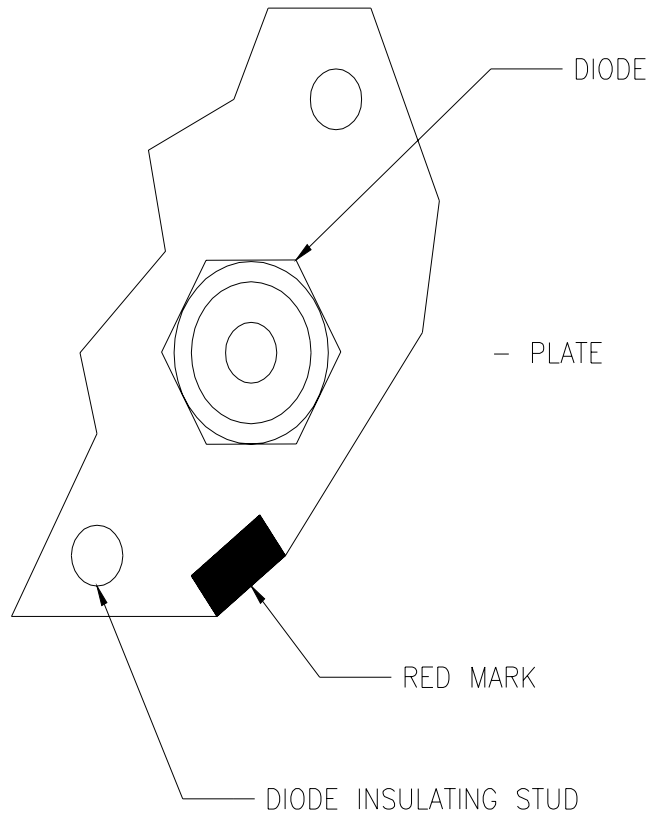

INSULATED TERMINAL IS INDICATED WITH A RED MARK

Figure 4