

Instruction Manual

Installation • Operation • Maintenance

Auto/Manual Modules

508-00106-00
508-00106-01
508-00106-04
508-00106-07
508-00106-08
508-00106-12
508-00106-17
508-00106-18
508-00106-19
508-00106-20



Leroy Somer North America

Kato Engineering Inc.
P.O. Box 8447
Mankato, MN USA
56002-8447
Tel: 507-625-4011
Fax: 507-345-2798
Email: katoengineering@lsusa.com
www.kato-eng.com

Note: Because of rapid changes in designs and processes and the variability of Kato Engineering's products, information in this manual must not be regarded as binding and is subject to change without notice.

Warning: *The voltage regulator sensing terminals are not disconnected from the generator when the switch in the MAN or OFF positions. Stop the generator set before making connections, repairs or adjustments. Failing to take such precautions can result in serious injury or death.*

Introduction

The auto/manual module is used to provide manual generator excitation control as a backup or the automatic voltage regulator. It is also used as an aid in troubleshooting the power system. Two operator controls are provided:

Auto/Off/Manual Selector Switch

Normal operation of the generator or motor-generator set is in the automatic mode. By moving this switch from AUTO to the MAN position, the operator disconnects the generator field from the automatic voltage regulator and connects it to the manual control circuitry. In the Off position, neither the regulator nor the manual control is connected to the field, thereby causing the generator voltage to decrease to a minimum value (unless the generator is paralleled with another source of power).

Manual Voltage Adjust

With the Auto/OFF/Manual switch in the manual position, the operator can use this control to vary the power fed to the exciter and, in turn, vary the generator voltage. All Kato auto/manual modules operate in the same manner. The differences between the various models (the different part numbers) are summarized in Table 1.

Connections

Make connections as follows (see Figures 1-3):

1. Connect the power source to terminals 1 and 2 of the module. Also connect power to terminals 7 and 8 on the modules that require dual inputs.
2. Connect the power input terminals of the voltage regulator to terminals 3 and 4 of the module.
3. Connect the voltage regulator output to terminals F+ and F- of the module.
4. Connect the exciter terminals F1 and F2 of the module.

Parts Replacement

If replacement parts are required, order them from the Kato factory. Please be sure to specify part and serial numbers. The following parts of the auto/manual module are replaceable:

Name	Part number
Rectifier assembly	851-31616-10
Discharge diode assembly.	851-31616-10
Surge suppressor	854-92737-06
Fuse 8 A	515-01208-31
Fuse 4 A	515-01204-31
Fuse 15 A	515-01215-31

Part Number	Power Input	Max Field Current	Voltage regulator compatibility	Fuse Rating	Fuse Qty.	Features
508-00106-00	120 V	10 A	KCR 160 KCR 360 KCR 760 KR4F SR4A K-65	8 A	1	
508-00106-01	Dual 120 V	10 A	KCR 760 KR7F SR8A K-125	8 A	2	
508-00106-04	240 V	5 A	KCR 760 KR7F SR8A K-125	4 A	1	
508-00106-07	120 V	10 A	KCR 160 KCR 360 KCR 760 KR4F SR4A K-65	8 A	1	Extra contacts available for customer use
508-00106-08	Dual 120 V	10 A	KCR 760 KR7F SR8A K-125	8 A	2	Extra contacts available for customer use
508-00106-12	240 V	5 A	KCR 760 KR7F SR8A K-125	4 A	1	Extra contacts available for customer use
508-00106-17	120 V	10 A	KCR 160 KCR 360 KCR 760 KR4F SR4A K-65	8 A	1	
508-00106-18	Dual 120 V	10 A	KCR 760 KR7F SR8A K-125	8 A	2	Customer supplied switch
508-00106-19	Dual 120 V	10 A	KCR 760 KR7F SR8A	8 A 15 A	1 1	
508-00106-20	Dual 120 V	10 A	KCR 760 KR7F SR8A K-125	8 A 15 A	1 1	Extra contacts available for customer use

Table 1: Differences between models

AMS CONTACTS			
CONTACT	AUTO	OFF	MANUAL
18-11	X		
12-13			X
14-15	X		
16-17			X
28-21	X		
22-23			X
24-25	X		
26-27			X
38-31	X		
31-32		X	
32-33			X
34-35	X		
35-36		X	
36-37			X
48-41	X		
41-42		X	
42-43			X
44-45	X		
45-46		X	
46-47			X

NOTE 1

NOTE 2

OPTIONAL "DRY" AMS SWITCH CONTACTS FOR CUSTOMER USE ARE SHOWN IN THE OFF POSITION. (SEE NOTES 1 & 2 BELOW)

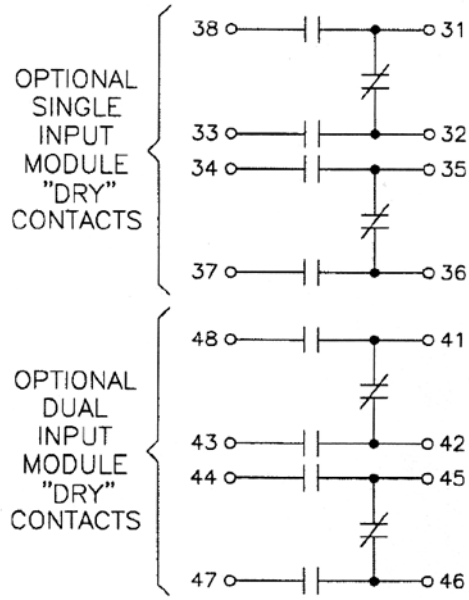

Notes:

1. Single input module - terminal numbers 31 through 38 are optional "dry contacts."
Dual input module - terminal numbers 31 through 38 are not available as "dry contacts."
2. Dual input module - terminal numbers 41 through 48 are optional "dry contacts."

Figure 1: Contacts

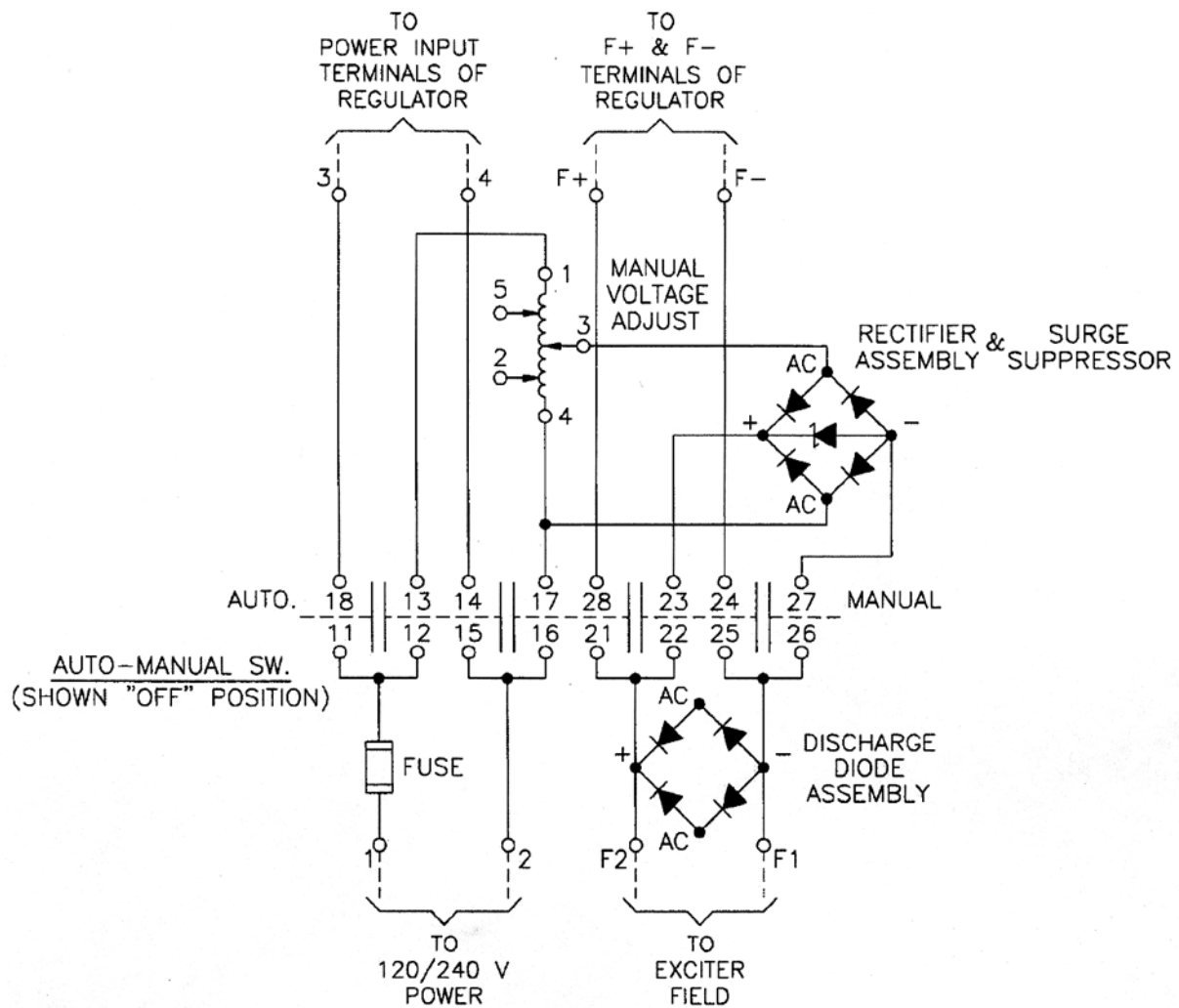

Figure 2: Wiring diagram for all single input modules

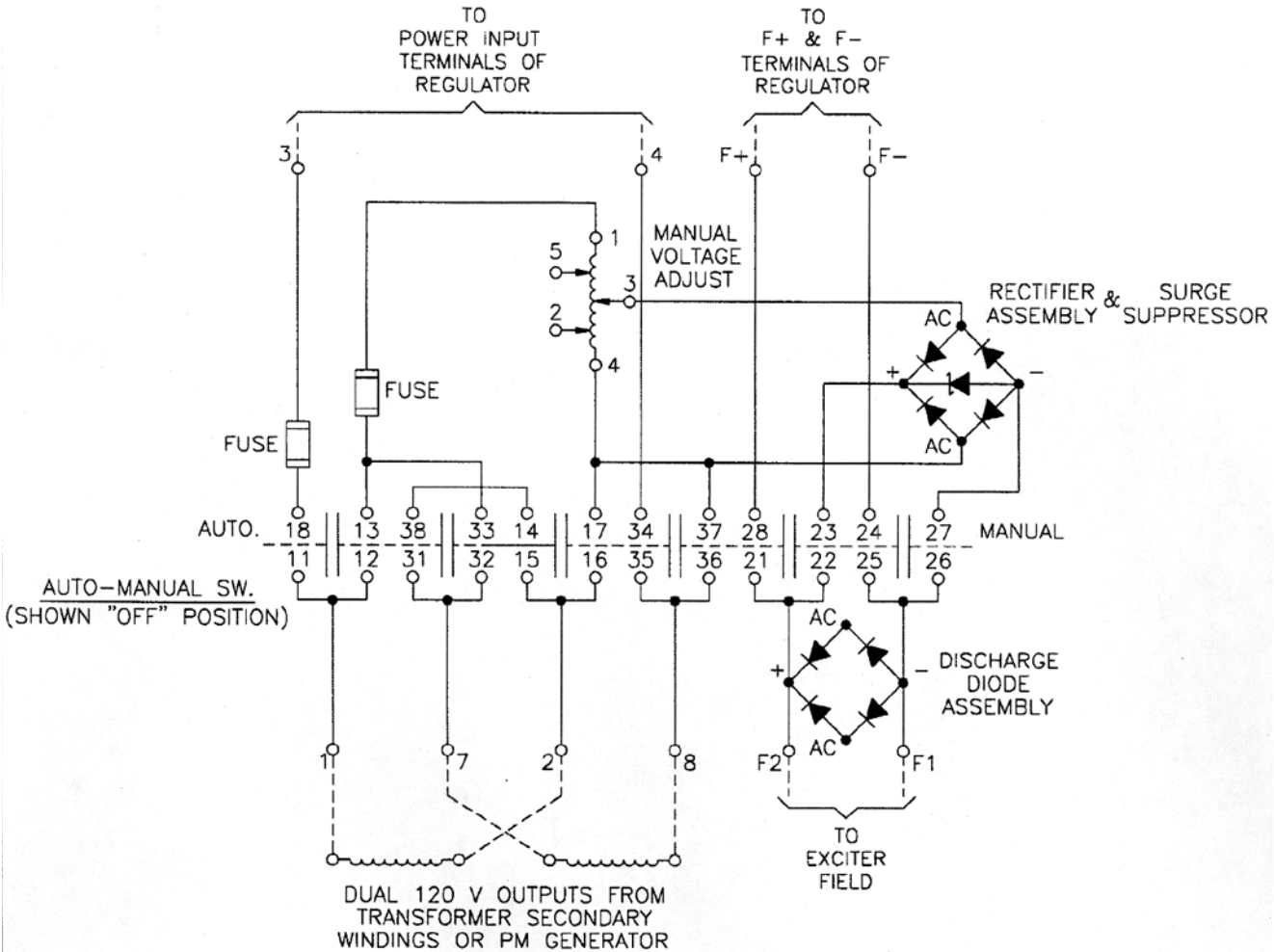
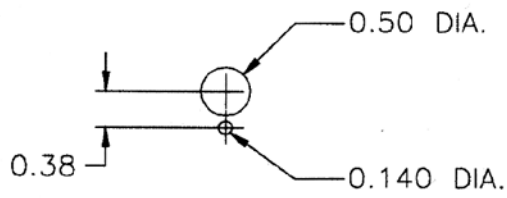
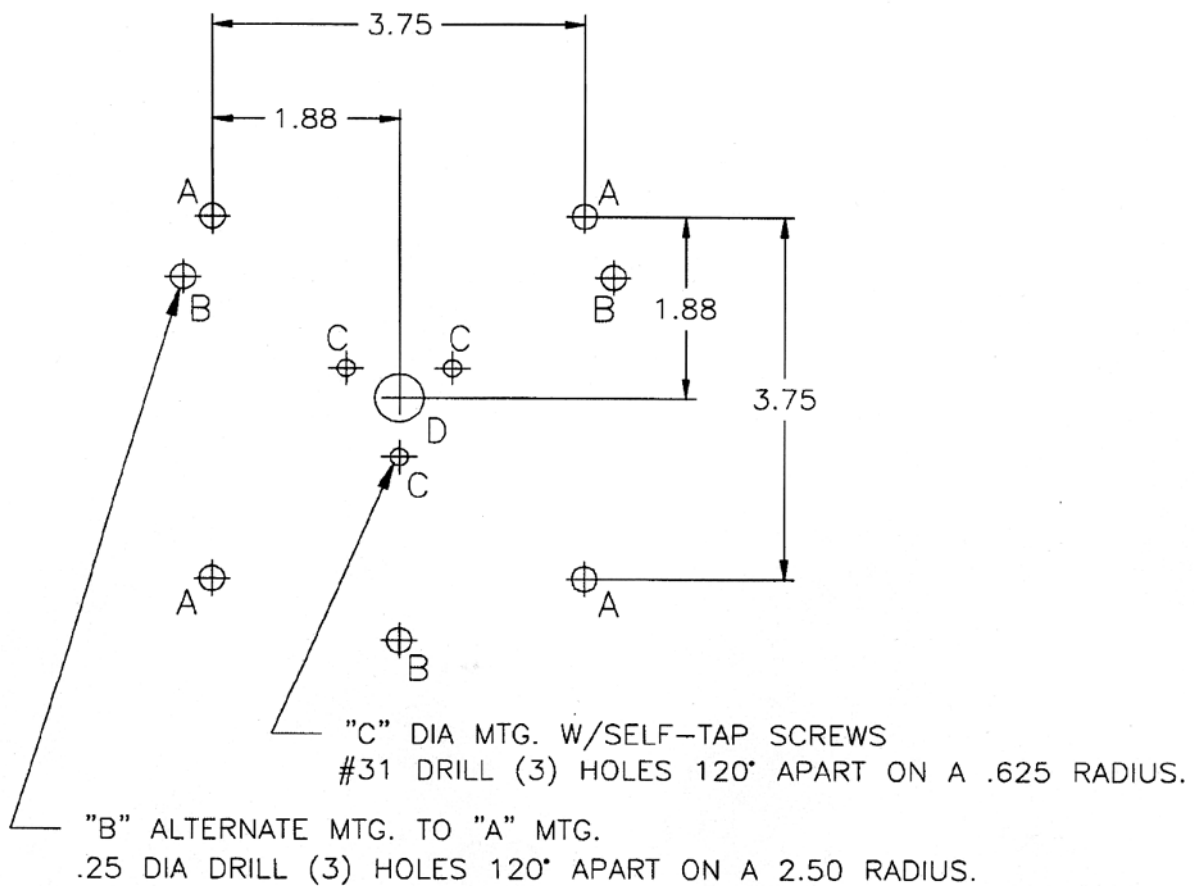

Figure 3: Wiring diagram for all dual input modules

SWITCH MTG.



VARIAC MTG.



"A" - .25 DIA.

"D" - .50 DIA.

Figure 4: Mounting dimensions